

Please refer to the **General Fabric Postcard Instructions** for all the techniques and general guidelines needed to make this project!

Squared Up Fabric Postcard Pattern

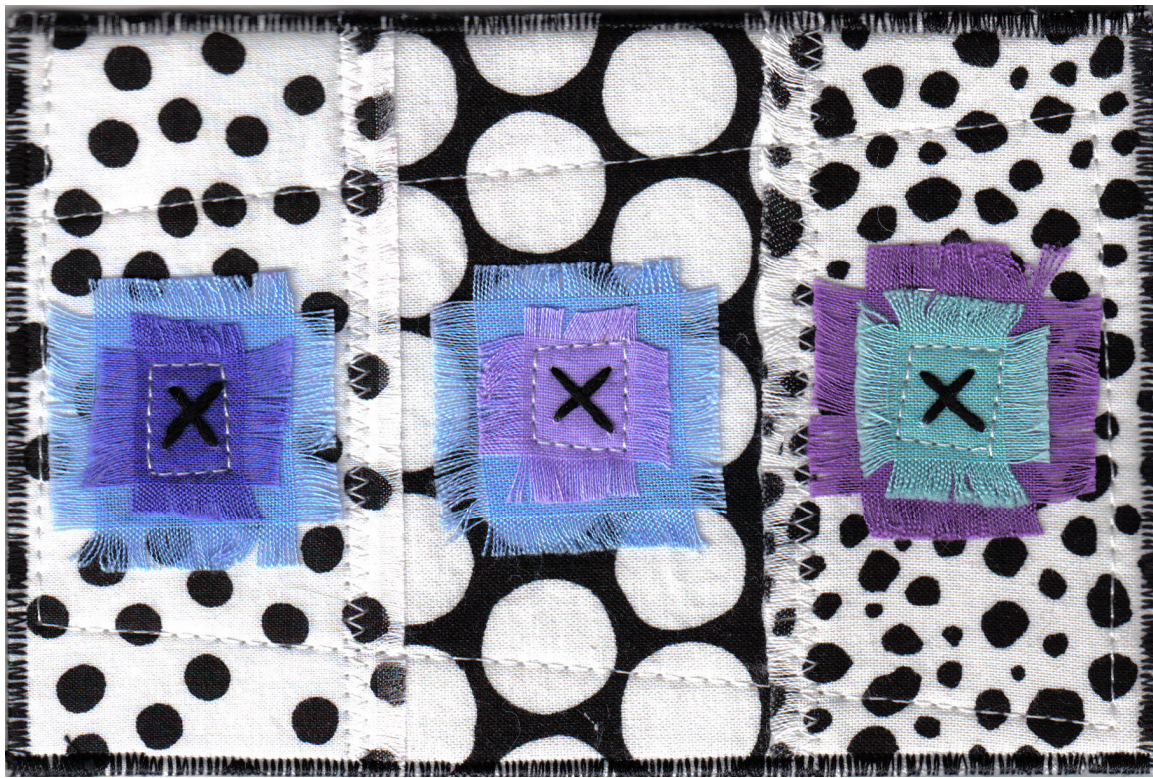

Please support the Alzheimer's Art Quilt Initiative!

Donate a fabric postcard to the Priority: Alzheimer's Quilts auction to fund Alzheimer's research.
<http://www.amisimms.com/alartquin.html> .

*Permission is hereby granted for individuals to use this pattern to make **Priority: Alzheimer's Quilts**. No further permission is required.*

For personal use only. In order to make or distribute copies of this PDF, whether printed or electronic, you must obtain written permission from Killer Bee Designs.

To Create the Squared Up Fabric Postcard:

1. Cut out the fabric pieces:
 - A. CUT 2: Piece A, 2 ¼" W x 4 ¼" H, Black and White Prints
 - B. CUT 1: Piece B, 2 ½" W x 4 ¼" H, Black and White Print
 - C. CUT 3: Piece C, 1 ½" W x 1 ½" H, Several Colors of Solid Fabrics
 - D. CUT 3: Piece D, 1" W x 1" H, Several Colors of Solid Fabrics
2. Fray the edges of Pieces C and D on all 4 edges by gently pulling off threads. I frayed them about 1/8" to ¼" on my piece.
3. Fray only one of the (long) 4 ¼" sides of Pieces A.
4. Place Piece B on the center third of the postcard. Place Pieces A on top of Piece B with the straight edges aligned with the right and left sides of the postcard. The frayed edges towards the center of the postcard as shown in the photo. Iron all 3 pieces to the fusible side of the Peltex.
5. Place a Piece D on top of a Piece C in each third of the postcard on the center horizontal line and move them around until you like your color arrangement. Using an UHU glue stick, lightly tack pieces D and C in place.
6. Hand or machine stitch the "X" motif in the center of each set of squares. I used 6 strands of black embroidery floss and hand stitched them.
7. Trim the edges back to your 4" x 6" postcard size with your rotary cutter.
8. Continue to quilt on the postcard either by hand or machine. Embellish, attach the back, finish the edges and go!

Placement Diagram

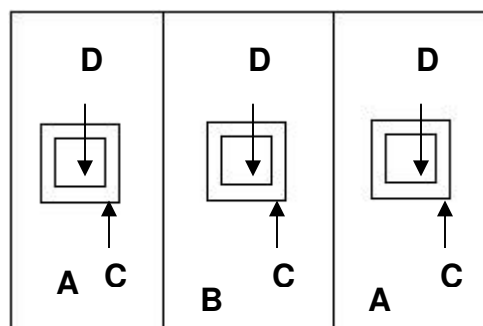

CUT 2: Piece A, 2 ¼" W x 4 ¼" H
CUT 1: Piece B, 2 ½" W x 4 ¼" H
CUT 3: Piece C, 1 ½" W x 1 ½" H
CUT 3: Piece D, 1" W x 1" H

For personal use only. In order to make or distribute copies of this PDF, whether printed or electronic, you must obtain written permission from Killer Bee Designs.